

1800 Series Double Fold-Up Support Bar+ Optional Toilet Roll Holder

<p>Models</p> <p><input type="checkbox"/> 01810 (<input type="checkbox"/>WH <input type="checkbox"/>BU) <input checked="" type="checkbox"/> 01830 (<input checked="" type="checkbox"/>WH <input checked="" type="checkbox"/>BU)</p> <p><input type="checkbox"/> 01820 (<input type="checkbox"/>WH <input type="checkbox"/>BU) <input type="checkbox"/> 01830 (<input type="checkbox"/>SS)</p>	<p>Code Compliance</p>
--	-------------------------------

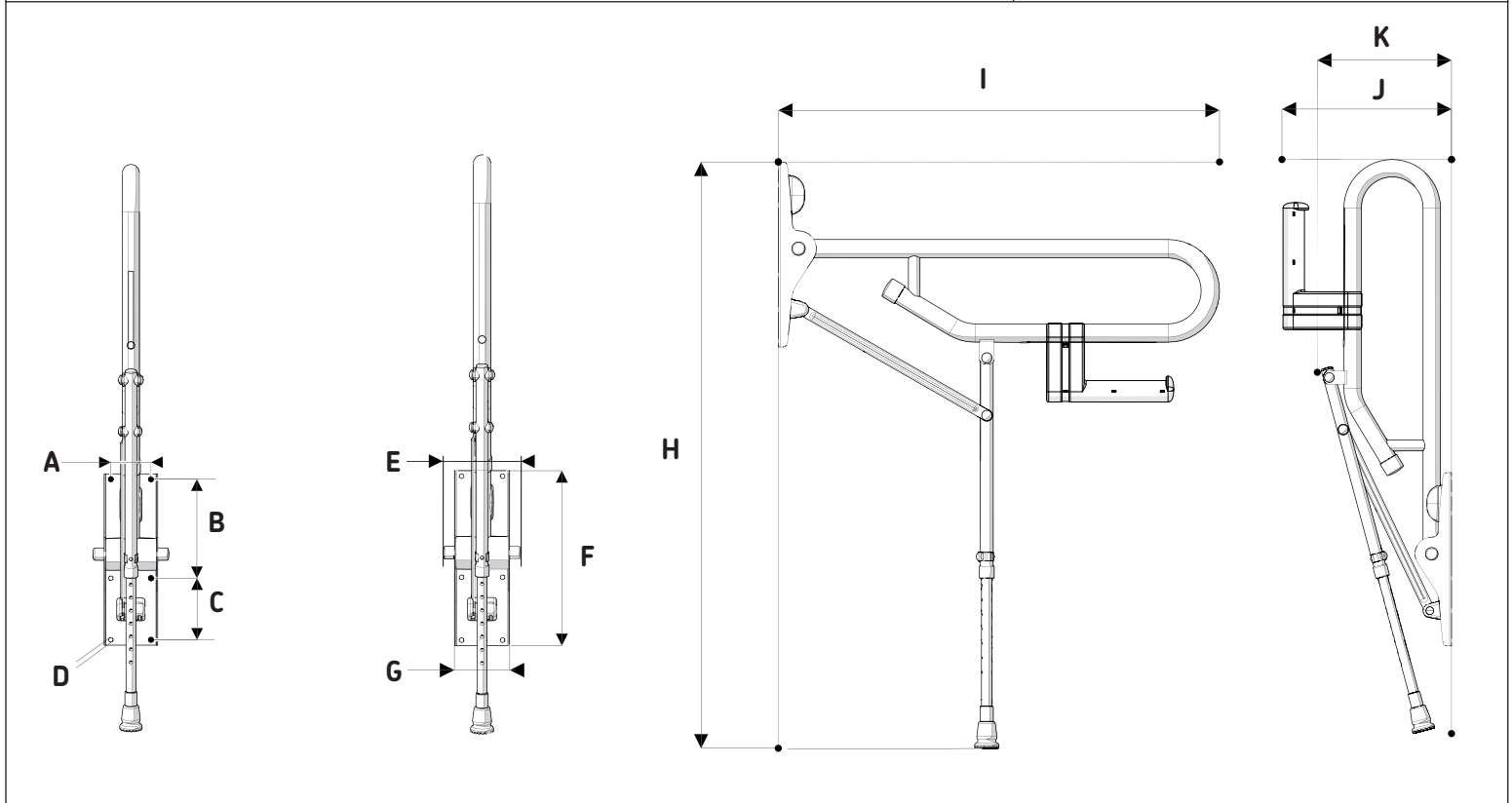

Fixing Plate Dimensions							Support Rail Dimensions			
A	B	C	D	E	F	G	H	I	J	K
3"	7 ³ / ₈ "	4 ¹ / ₂ "	³ / ₈ " diam	5 ¹ / ₂ "	12 ¹ / ₂ "	4"	26 ³ / ₄ "-34 ³ / ₄ "	30 ¹ / ₈ "	11 ¹ / ₂ "	10"
75mm	185mm	115mm	8.5mm diam	142mm	320mm	100mm	680-880mm	765mm	290mm	255mm

<p>Technical Specifications</p> <p>Composition: Shipped Weight: 10lbs Handing: Non -handed Weight capacity: 220kg/ 440lbs when properly fastened to blocking/concrete Colors: White or Blue Warranties: 10 years for residential use or 5 years for commercial use</p>	<p>Features</p> <ul style="list-style-type: none"> • Folds neatly back to wall when not in use • Supporting leg for additional strength and stability • Leg adjusts in 25mm ³/₄" increments • + / - ¹/₂" fine adjustment to foot of support leg • Includes toilet roll holder for convenience 	<p>Recommended Accessories</p> <p><input type="checkbox"/> Heavy-Duty Grab Bar</p> <p><input type="checkbox"/></p> <p><input type="checkbox"/></p>
---	---	---